

Phoenix Inverter VE. Bus enabled

24 | 3000 | 120V

Copyrights © 2007 Victron Energy B.V.
All Rights Reserved

This publication or parts thereof may not be reproduced in any form, by any method, for any purpose.

For conditions of use and permission to use this manual for publication in other than the English language, contact Victron Energy B.V.

VICTRON ENERGY B.V. MAKES NO WARRANTY, EITHER EXPRESSED OR IMPLIED, INCLUDING BUT NOT LIMITED TO ANY IMPLIED WARRANTIES OF MERCHANTABILITY OR FITNESS FOR A PARTICULAR PURPOSE, REGARDING THESE VICTRON ENERGY PRODUCTS AND MAKES SUCH VICTRON ENERGY PRODUCTS AVAILABLE SOLELY ON AN "AS IS" BASIS.

IN NO EVENT SHALL VICTRON ENERGY B.V. BE LIABLE TO ANYONE FOR SPECIAL, COLLATERAL, INCIDENTAL, OR CONSEQUENTIAL DAMAGES IN CONNECTION WITH OR ARISING OUT OF PURCHASE OR USE OF THESE VICTRON ENERGY PRODUCTS. THE SOLE AND EXCLUSIVE LIABILITY TO VICTRON ENERGY B.V., REGARDLESS OF THE FORM OF ACTION, SHALL NOT EXCEED THE PURCHASE PRICE OF THE VICTRON ENERGY PRODUCTS DESCRIBED HERE IN.

Victron Energy B.V. reserves the right to revise and improve its products as it sees fit. This publication describes the state of this product at the time of its publication and may not reflect the product at all times in the future

1. SAFETY INSTRUCTIONS

In general

Please read the documentation supplied with this product first, so that you are familiar with the safety signs and directions before using the product.

This product is designed and tested in accordance with international standards. The equipment should be used for the designated application only.

WARNING: DANGER OF ELECTRICAL SHOCK

The product is used in combination with a permanent energy source (battery). Even if the equipment is switched off, a dangerous electrical voltage can occur at the input and/or output terminals. Always switch the AC power off and disconnect the battery before performing maintenance.

The product contains no internal user-serviceable parts. Do not remove the front panel and do not put the product into operation unless all panels are fitted. All maintenance should be performed by qualified personnel.

Never use the product at sites where gas or dust explosions could occur. Refer to the specifications provided by the manufacturer of the battery to ensure that the battery is suitable for use with this product. The battery manufacturer's safety instructions should always be observed.

WARNING: do not lift heavy objects unassisted.

Installation

Read the installation instructions before commencing installation activities.

This product is a safety class I device (supplied with a ground terminal for safety purposes). **The chassis must be grounded.** A grounding point is located on the outside of the product. If it can be assumed that the grounding protection is damaged, the product should be taken out of operation and prevented from accidentally being put into operation again; contact qualified maintenance personnel.

Ensure that the connection cables are provided with fuses and circuit breakers. Never replace a protective device by a component of a different type. Refer to the manual for the correct part.

Check before switching the device on whether the available voltage source conforms to the configuration settings of the product as described in the manual.

Ensure that the equipment is used under the correct operating conditions. Never operate it in a wet or dusty environment.

Ensure that there is always sufficient free space around the product for ventilation, and that ventilation openings are not blocked.

Install the product in a heatproof environment. Ensure therefore that there are no chemicals, plastic parts, curtains or other textiles, etc. in the immediate vicinity of the equipment.

Transport and storage

On storage or transport of the product, ensure that the battery leads are disconnected.

No liability can be accepted for damage in transit if the equipment is not transported in its original packaging.

Store the product in a dry environment; the storage temperature should range from – 20°C to 60°C.

Refer to the battery manufacturer's manual for information on transport, storage, charging, recharging and disposal of the battery.

2. DESCRIPTION

SinusMax - Superior engineering

Developed for professional duty, the Phoenix range of inverters is suitable for the widest range of applications. The design criteria have been to produce a true sine wave inverter with optimised efficiency but without compromise in performance. Employing hybrid HF technology, the result is a top quality product with compact dimensions, light in weight and capable of supplying power, problem-free, to any load.

Extra start-up power

A unique feature of the SinusMax technology is very high start-up power. Conventional high frequency technology does not offer such extreme performance. Phoenix inverters, however, are well suited to power up difficult loads such as compressors, electric motors and similar appliances.

Virtually unlimited power thanks to parallel and 3-phase operation capability

Up to 6 inverters can operate in parallel to achieve higher power output. Six 24/3000 units, for example, will provide 18 kVA output power. Operation in 3-phase configuration is also possible.

To transfer the load to another AC source: the automatic transfer switch

If an automatic transfer switch is required, we recommend to using the MultiPlus or Quattro instead. The switch is included in these products and the charger function of the MultiPlus/Quattro can be disabled. Computers and other electronic equipment will continue to operate without disruption because the MultiPlus/Quattro features a very short switchover time (less than 20 milliseconds).

Programmable relay

The Phoenix Inverter is equipped with a programmable relay, which by default is set as an alarm relay. The relay can be programmed for all kinds of other applications however, for example as a starter relay for a generating set.

Programmable with DIP switches, VE.Net panel or personal computer

The Phoenix Inverter is supplied ready for use. Three features are available for changing certain settings if desired:

- The most important settings (including parallel operation of up to three devices and 3-phase operation) can be changed in a very simple manner, using DIP switches.
- All settings, with exception of the programmable relay, can be changed with a VE.Net panel.
- All settings can be changed with a PC and free of charge software, downloadable from our website www.victronenergy.com

3. OPERATION

3.1 On/Off Switch

When switched to "on", the product is fully functional. The inverter will come into operation and the LED "inverter on" will light up.

3.2 Remote control

Remote control is possible with a simple on/off switch or with a Phoenix Inverter Control panel.

3.3 LED Indications

- LED off
- LED flashes
- LED illuminated

Inverter

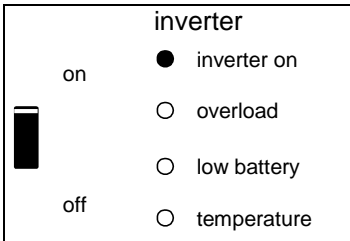

The inverter is on and supplies power to the load.

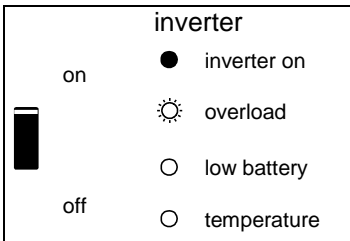

The nominal output of the inverter is exceeded. The "overload" LED flashes.

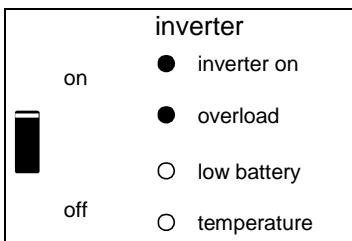

The inverter is switched off due to overload or short circuit.

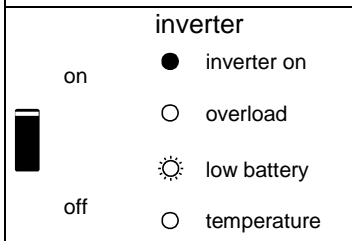

The battery is almost fully exhausted.

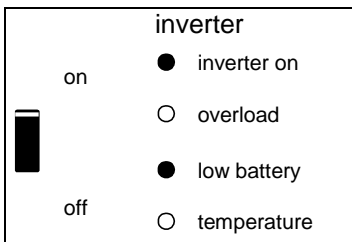

The inverter has switched off due to low battery voltage.

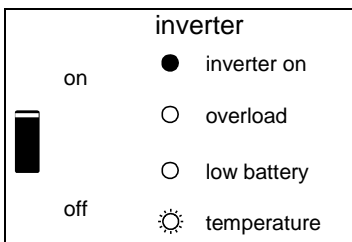

The internal temperature is reaching a critical level.

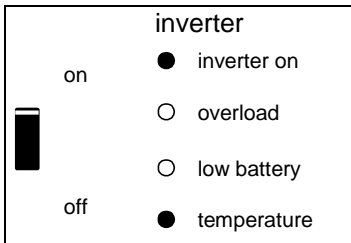

The inverter has switched off due to the electronics temperature being too high.

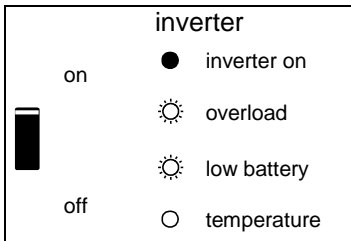

-If the LEDs are flashing alternately, the battery is nearly exhausted and the nominal output is exceeded.
-If "overload" and "low battery" flash simultaneously, the ripple voltage on the battery terminals is too high.

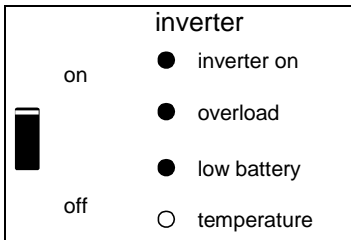

The inverter switched off due to excess ripple voltage on the battery terminals.

4. INSTALLATION



This product may only be installed by a qualified electrical engineer.

4.1 Location

The product must be installed in a dry and well-ventilated area, as close as possible to the batteries. There should be a clear space of at least 10 cm around the appliance for cooling.



Excessively high ambient temperature will result in the following:

- Reduced service life.
- Reduced peak capacity, or shutdown of the inverter.

Never position the appliance directly above the batteries.

The Phoenix Inverter is suitable for wall mounting. For mounting purposes, a hook and two holes are provided at the back of the casing (see appendix G). The device can be fitted either horizontally or vertically. For optimal cooling, vertical fitting is preferred.



The interior of the product must remain accessible after installation.

Try to keep the distance between the product and the battery to a minimum in order to minimize cable voltage losses.



For safety purposes, this product should be installed in a heat-resistant environment. You should prevent the presence of e.g. chemicals, synthetic components, curtains or other textiles, etc., in the immediate vicinity.

4.2 Connection of battery cables

In order to utilize the full capacity of the product, batteries with sufficient capacity and battery cables with sufficient cross section should be used. See table.

	24/3000
Recommended battery capacity (Ah)	200–700
Recommended DC fuse	300A
Recommended cross-section (mm ²) per + and - connection terminal	
0 – 5 m	50 mm ²
5 – 10 m	2x 50 mm ²

* '2x' means two positive and two negative cables.

Remark: Internal resistance is the important factor when working with low capacity batteries. Please consult your supplier or the relevant sections of our book "electricity on board", downloadable from our website.

Procedure

Proceed as follows to connect the battery cables:



Use an insulated box spanner in order to avoid shorting the battery.
Avoid shorting the battery cables.

- Undo the four screws at the front of the enclosure and remove the front panel.
- Connect the battery cables: see Appendix A.
- Tighten the nuts well for minimal contact resistance.

4.3 Connection of the AC cabling

This is a Safety Class I product (supplied with a protective grounding terminal).



The neutral output of the inverter is connected to the enclosure.

This to ensure proper functioning of a GFCI (or RCCB) to be installed in the AC output of the Inverter.

The chassis of the product must be connected to ground, or the frame (of a vehicle) or the ground plate or hull (of a boat).

The terminal block can be found on the printed circuit board, see Appendix A. Use a three-wire cable with a flexible core and a cross section of 2.5 or 4 mm²

Procedure

The AC output cable can be connected directly to the terminal block "AC-out".

4.4 Optional Connections

A number of optional connections are possible:

4.4.1 Remote Control

The product can be remotely controlled in two ways.

- With an external switch (connection terminal H, see appendix A). Operates only if the switch on the Inverter is set to "on".
- With a Phoenix Inverter Control panel (connected to one of the two RJ48 sockets C, see appendix A). Operates only if the switch on the inverter is set to "on".

Only one remote control can be connected, i.e. either a switch or a remote control panel.

4.4.2. Programmable relay

The inverters are equipped with a multi-functional relay that by default is programmed as an alarm relay. (VEConfigure software needed to change relay functionality).

4.4.3 Parallel Connection

The Phoenix Inverter can be connected in parallel with several identical devices. To this end, a connection is established between the devices by means of standard RJ45 UTP cables. The **system** (Two or more Inverters plus optional control panel) will require subsequent configuration (see Section 5).

In the event of connecting units in parallel, the following requirements must be met:

- A maximum of six units connected in parallel.
- Only identical devices with the same power ratings may be connected in parallel.
- Battery capacity should be sufficient.
- The DC connection cables to the devices must be of equal length and cross-section.
- If a positive and a negative DC distribution point is used, the cross-section of the connection between the batteries and the DC distribution point must at least equal the sum of the required cross-sections of the connections between the distribution point and the Inverter units.
- Place the units close to each other, but allow at least 10 cm for ventilation purposes under, above and beside the units.
- UTP cables must be connected directly from one unit to the other (and to the remote panel). Connection/splitter boxes are not permitted.
- Only one remote control means (panel or switch) can be connected to the system.

4.4.4 Three-phase operation

The Phoenix Inverter can also be used in 3-phase configuration. To this end, a connection between the devices is made by means of standard RJ45 UTP cables (the same as for parallel operation). The **system** (Inverters plus an optional control panel) will require subsequently configuration (see Section 5).

Pre-requisites: see Section 4.4.3.

5. CONFIGURATION



- Settings may only be changed by a qualified electrical engineer.
- Read the instructions thoroughly before implementing changes.

5.1 Standard settings: ready for use

On delivery, the Phoenix Inverter is set to standard factory values. In general, these settings are suitable for stand-alone operation.

Standard factory settings

Inverter frequency	60 Hz
Inverter voltage	120 VAC
Stand-alone / parallel / 3-phase	stand-alone
AES (Automatic Economy Switch)	off
Programmable relay	alarm function

5.2 Explanation of settings

Settings that are not self-explanatory are described briefly below. For further information, please refer to the help files in the software configuration programs (see Section 5.3).

Inverter frequency

Output frequency
Adjustability: 50Hz; 60Hz

Inverter voltage

Output voltage of the Inverter.
Adjustability: 95 –128V

Stand-alone / parallel operation / 2-3 phase setting

Using several devices, it is possible to:

- increase total inverter power (several devices in parallel)
- create a 3-phase system.

To this end, the devices must be mutually connected with RJ45 UTP cables. Standard device settings, however, are such that each device operates in stand-alone operation. Reconfiguration of the devices is therefore required.

AES (Automatic Economy Switch)

If this setting is turned 'on', the power consumption in no-load operation and with low loads is decreased by approx. 20%, by slightly 'narrowing' the sinusoidal voltage. The AES Mode can be set with a DIP switch. Applicable in stand-alone configuration only.

Search Mode (Applicable in stand-alone configuration only)

If search mode is 'on', the power consumption in no-load operation is decreased by approx. 70%. In this mode the Compact, when operating in inverter mode, is switched off in case of no load or very low load, and switches on every two seconds for a short period. If the output current exceeds a set level, the inverter will continue to operate. If not, the inverter will shut down again.

Not adjustable with DIP switches.

The Search Mode "shut down" and "remain on" load levels can be set with VEConfigure.

The standard settings are:

Shut down: 40 Watt (linear load)

Turn on: 100 Watt (linear load)

Programmable relay

By default, the programmable relay is set as an alarm relay, i.e. the relay will de-energise in the event of an alarm or a pre-alarm (inverter almost too hot, ripple on the input almost too high, battery voltage almost too low). Not adjustable with DIP switches.

5.3 Configuration by computer

All settings can be changed by means of a computer or with a VE.Net panel (except for the multi-functional relay and the VirtualSwitch when using VE.Net).

The most common settings (including parallel and 3-phase operation) can be changed by means of DIP switches (see Section 5.5).

For changing settings with the computer, the following is required:

- VEConfigureII software. You can download the VEConfigureII software free of charge at www.victronenergy.com.
- A RJ45 UTP cable and the **MK2.2b** RS485-to-RS232 interface. If your computer has no RS232 connection, but does have USB, you will also need a **RS232-to-USB interface cable**. Both are available from Victron Energy.

5.3.1 VE.Bus Quick Configure Setup

VE.Bus Quick Configure Setup is a software program with which systems with a maximum of three Phoenix Inverters (parallel or three phase operation) can be configured in a simple manner. VEConfigureII forms part of this program.

You can download the software free of charge at www.victronenergy.com.

For connection to your computer, a RJ45 UTP cable and the **MK2.2b** RS485-to-RS232 interface is required.

If your computer does not have a RS232 connection but is equipped with USB, you will also need a **RS232-to-USB interface cable**. Both are available from Victron Energy.



5.3.2 VE.Bus System Configurator and dongle

For configuring advanced applications and/or systems with four or more Inverters, **VE.Bus System Configurator** software must be used. You can download the software at www.victronenergy.com. VEConfigureII forms part of this program. You can configure the system without a dongle, and use it for 15 minutes (as a demonstration facility). For permanent use, a dongle – available at additional charge – is required.

For connection to your computer, a RJ45 UTP cable and the **MK2.2b** RS485-to-RS232 interface is required.

If your computer does not have a RS232 connection but is equipped with USB, you will also need a **RS232-to-USB interface cable**.

Both are available from Victron Energy.

5.4 Implementing settings with a VE.Net panel

To this end, a VE.Net panel and the VE.Net to VE.Bus converter is required.

With VE.Net you can set all parameters, with the exception of the multi-functional relay and the VirtualSwitch.

5.5 Configuration with DIP switches

A number of settings can be changed using DIP switches (see appendix A, position I).

Procedure:

- Turn the Inverter on, preferably unloaded.
- Set the DIP switches for:
 - AES (Automatic Economy Switch)
 - Inverter voltage
 - Inverter frequency
 - selection of stand-alone, parallel or 3-phase operation.
- To store the settings after the required values have been set: press the 'Up' button for 2 seconds (**upper** button to the right of the DIP switches, see appendix A, position J).

Remarks:

- Dipswitches ds8, ds7 and ds6 are not assigned and should remain off.
- The DIP switch functions are described in 'top to bottom' order. Since the uppermost DIP switch has the highest number (8), descriptions start with the switch numbered 5.
- In parallel mode or 3-phase mode, not all devices require all settings to be made (see section 5.5.4).
- For parallel or 3-phase mode, read the whole setting procedure and make a note of the required DIP switch settings before actually implementing them.
- The 'down' button is not used in this procedure and must not be pressed!

5.5.1 AES (Automatic Economy Switch)

Procedure: set ds5 to the required value:

ds5

off = AES off

on = AES on

Note: The AES option is only effective if the unit is used 'stand alone'.

5.5.2 Inverter voltage

Procedure: set ds4 to the required value:

ds4

off = 115V

on = 120V

5.5.3 Inverter frequency

Procedure: set ds3 to the required value:

ds3

off = 60Hz

on = 50Hz

5.5.4 Stand-alone, parallel and 3-phase operation

DIP switches ds2 and ds1 are reserved for the selection of stand-alone, parallel or 3-phase operation

NOTE:

- When configuring a parallel or 3-phase system, all related devices should be interconnected using RJ45 UTP cables (see appendix C, D). All devices must be turned on. They will subsequently return an error code (see Section 7), since they have been integrated into a system and still are configured as 'stand-alone'. This error message can safely be ignored.
- Storing settings (by pressing the 'Up' button for 2 seconds) should be done on one device only. This device is the 'master' in a parallel system or the 'leader' (L1) in a 3-phase system.
In a parallel system, the setting of DIP switches ds5 to ds3 need to be done on the master only. The slaves will follow the master with regard to these settings (hence the master/slave relationship).
In a 3-phase system, the 'Inverter voltage setting' is required for the other devices, i.e. the followers (for phases L2 and L3).
(The followers, therefore, do not follow the leader for all settings, hence the leader/follower terminology).
- A change in the setting 'stand-alone / parallel / 3-phase' is only activated after the setting has been stored (by pressing the 'UP' button for 2 seconds) **and** after all devices have been turned off and then on again. In order to start up a VE.Bus system correctly, all devices should therefore be turned off after the settings have been stored. They can then be turned on in any order. The system will not start until all devices have been turned on.
- Note that only identical devices can be integrated in one system. Any attempt to use different models in one system will fail. Such devices may possibly function correctly again only after individual reconfiguration for 'stand-alone' operation.
- The combination **ds2=on** and **ds1=on** is not used.



victron energy

Setting ds2 and ds1 for stand-alone operation

DS-8 not used	Set off	<input type="checkbox"/>
DS-7 not used	Set off	<input type="checkbox"/>
DS-6 not used	Set off	<input type="checkbox"/>
DS-5 AES	Set as desired	<input type="checkbox"/>
DS-4 Inverter voltage	Set as desired	<input type="checkbox"/>
DS-3 Inverter frequency	Set as desired	<input type="checkbox"/>
DS-2 Stand-alone operation		<input type="checkbox"/>
DS-1 Stand-alone operation		<input type="checkbox"/>

Examples of DIP switch settings for stand-alone mode are given below.

Example 1 shows the factory setting (since factory settings are entered by computer, all DIP switches of a new product are set to 'off').

Four examples of stand-alone settings:

DS-8 not used <input type="checkbox"/> off DS-7 not used <input type="checkbox"/> off DS-6 not used <input type="checkbox"/> off DS-5 AES <input type="checkbox"/> off DS-4 Inverter voltage <input type="checkbox"/> on DS-3 Inverter frequency <input type="checkbox"/> on DS-2 Stand-alone mode <input type="checkbox"/> off DS-1 Stand-alone mode <input type="checkbox"/> off	DS-8 <input type="checkbox"/> off DS-7 <input type="checkbox"/> off DS-6 <input type="checkbox"/> off DS-5 <input type="checkbox"/> off DS-4 <input type="checkbox"/> off DS-3 <input type="checkbox"/> off DS-2 <input type="checkbox"/> off DS-1 <input type="checkbox"/> off	DS-8 <input type="checkbox"/> off DS-7 <input type="checkbox"/> off DS-6 <input type="checkbox"/> off DS-5 <input type="checkbox"/> off DS-4 <input type="checkbox"/> on DS-3 <input type="checkbox"/> off DS-2 <input type="checkbox"/> off DS-1 <input type="checkbox"/> off	DS-8 <input type="checkbox"/> off DS-7 <input type="checkbox"/> off DS-6 <input type="checkbox"/> off DS-5 <input type="checkbox"/> on DS-4 <input type="checkbox"/> off DS-3 <input type="checkbox"/> on DS-2 <input type="checkbox"/> off DS-1 <input type="checkbox"/> off
stand-alone Example 1 (factory setting): 5 AES: off 4 Inverter voltage 120V 3 Inverter frequency 50Hz 2, 1 Stand-alone mode	stand-alone Example 2: 5 AES: off 4 115V 3 60Hz 2,1 Stand-alone	stand-alone Example 3: 5 AES: off 4 120V 3 60Hz 2,1 Stand-alone	stand-alone Example 4: 5 AES: on 4 115V 3 50Hz 2,1 Stand-alone

To store the settings after the required values have been set: press the 'Up' button for 2 seconds (**upper** button to the right of the DIP switches, see appendix A, position J). **The overload and low-battery LED's will flash to indicate acceptance of the settings.**

You can leave the DIP switches in the selected positions, so that the settings can always be recovered.

Setting ds2 and ds1 for parallel operation

Master		Slave 1	Slave 2 (optional)
DS-8 not used	<input type="checkbox"/>	DS-8 not used	<input type="checkbox"/>
DS-7 not used	<input type="checkbox"/>	DS-7 not used	<input type="checkbox"/>
DS-6 not used	<input type="checkbox"/>	DS-6 not used	<input type="checkbox"/>
DS-5 AES na	<input checked="" type="checkbox"/>	DS-5 na	<input checked="" type="checkbox"/>
DS-4 Inv. voltage Set	<input type="checkbox"/>	DS-4 na	<input checked="" type="checkbox"/>
DS-3 Inv. freq Set	<input type="checkbox"/>	DS-3 na	<input checked="" type="checkbox"/>
DS-2 Master	<input type="checkbox"/>	DS-2 Slave 1	<input type="checkbox"/>
DS-1 Master	<input checked="" type="checkbox"/>	DS-1 Slave 1	<input type="checkbox"/>

To store the settings after the required values have been set: press the 'Up' button of the **master** for 2 seconds (**upper** button to the right of the DIP switches, see appendix A, position J). **The overload and low-battery LED's will flash to indicate acceptance of the settings.**

You can leave the DIP switches in the selected positions, so that the settings can always be recovered.

Setting ds2 and ds1 for 3-phase operation

Leader (L1)		Follower (L2)	Follower (L3)
DS-8 not used	<input type="checkbox"/>	DS-8 not used	<input type="checkbox"/>
DS-7 not used	<input type="checkbox"/>	DS-7 not used	<input type="checkbox"/>
DS-6 not used	<input type="checkbox"/>	DS-6 not used	<input type="checkbox"/>
DS-5 AES na	<input checked="" type="checkbox"/>	DS-5 na	<input checked="" type="checkbox"/>
DS-4 Inv. voltage Set	<input type="checkbox"/>	DS-4 Set	<input type="checkbox"/>
DS-3 Inv. freq Set	<input type="checkbox"/>	DS-3 na	<input checked="" type="checkbox"/>
DS-2 Leader	<input checked="" type="checkbox"/>	DS-2 L2	<input type="checkbox"/>
DS-1 Leader	<input type="checkbox"/>	DS-1 L2	<input type="checkbox"/>

As the table above shows, the Inverter voltage should be set separately (ds4) for every Inverter AES can be used on stand alone units only.

To store the settings after the required values have been set: press the 'Up' button of the **Leader** for 2 seconds (**upper** button to the right of the DIP switches, see appendix A, position J). **The overload and low-battery LED's will flash to indicate acceptance of the settings.**

You can leave the DIP switches in the selected positions, so that the settings can always be recovered.

To start the system: first, turn all devices off. The system will start up as soon as all devices have been turned on.

6. MAINTENANCE

The Phoenix Inverter does not require specific maintenance. It will suffice to check all connections once a year. Avoid moisture and oil/soot/vapours, and keep the device clean.

7. FAULT INDICATIONS

With the procedures below, most errors can be quickly identified. If an error cannot be resolved, please refer to your Victron Energy supplier.

7.1 General error indications

Problem	Cause	Solution
Inverter operation not initiated when switched on.	The battery voltage is excessively high or too low. No voltage on DC connection.	Ensure that the battery voltage is within the correct range.
"Low battery" LED flashes.	The battery voltage is low.	Charge the battery or check the battery connections.
"Low battery" LED lights.	The converter switches off because the battery voltage is too low.	Charge the battery or check the battery connections.
"Overload" LED flashes.	The converter load is higher than the nominal load.	Reduce the load.
"Overload" LED lights.	The converter is switched off due to excessively high load.	Reduce the load.
"Temperature" LED flashes or lights.	The environmental temperature is high, or the load is too high.	Install the converter in cool and well-ventilated environment, or reduce the load.
"Low battery" and "overload" LEDs flash intermittently.	Low battery voltage and excessively high load.	Charge the batteries, disconnect or reduce the load, or install higher capacity batteries. Fit shorter and/or thicker battery cables.
"Low battery" and "overload" LEDs flash simultaneously.	Ripple voltage on the DC connection exceeds 1,5Vrms.	Check the battery cables and battery connections. Check whether battery capacity is sufficiently high, and increase this if necessary.
"Low battery" and "overload" LEDs light.	The inverter is switched off due to an excessively high ripple voltage on the input.	Install batteries with a larger capacity. Fit shorter and/or thicker battery cables, and reset the inverter (switch off, and then on again).
One alarm LED lights and the second flashes.	The inverter is switched off due to alarm activation by the lighted LED. The flashing LED indicates that the inverter was about to switch off due to the related alarm.	Check this table for appropriate measures in regard to this alarm state.

7.2 VE.Bus LED indications

Inverters included in a VE.Bus system (a parallel or 3-phase arrangement) can provide so-called VE.Bus LED indications. These LED indications can be subdivided into two groups: OK codes and error codes.

7.2.1 VE.Bus OK codes

If the internal status of a device is in order but the device cannot yet be started because one or more other devices in the system indicate an error status, the devices that are in order will indicate an OK code. This facilitates error tracing in a VE.Bus system, since devices not requiring attention are easily identified as such.

Important: OK codes will only be displayed if a device is not inverting!

- The "inverter on" LED must flash.
- A flashing "overload" LED indicates that the device can perform inverter operation.
- A flashing "temperature" LED indicates that the device is not blocking charge operation. (This is just a formal indication which originates from the relationship with the Phoenix Multi. This indication has no special meaning on a Phoenix Inverter)

NOTE: The "low battery" LED can function together with the OK code that indicates that the device does not block charge.

7.2.2 VE.Bus error codes

If a VE.Bus error occurs (example: a broken UTP cable) the system will switch off and the 'inverter on' LED will flash.

If such an error occurs one should switch all units off, verify all cabling and switch the units on again.

Additional information about the error can be retrieved from the Inverter with the **VE.BUS System Configurator** or the **VE.BUS Quick Configure** tool.

8. TECHNICAL SPECIFICATIONS

Phoenix Inverter	24/3000
INVERTER	
Input voltage range (V DC)	19 – 33
Output (1)	Output voltage: 120 VAC \pm 2% Frequency: 60 Hz \pm 0,1%
Cont. output power at 25 °C (VA) (3)	3000
Cont. output power at 25 °C (W)	2500
Cont. output power at 40 °C (W)	2000
Peak power (W)	6000
Maximum efficiency (%)	94
Zero-load power (W)	15
GENERAL	
Programmable relay (4)	Yes
Protection (2)	a - g
Common Characteristics	Operating temp.: -20 to +50°C (fan assisted cooling) Humidity (non condensing) : max 95%
ENCLOSURE	
Common Characteristics	Material & Colour: aluminium (blue RAL 5012) Protection: IP 21
Battery-connection	M8 bolts (2 plus and 2 minus connections)
230 V AC-connection	Screw terminals 13mm ² (6 AWG)
Weight (kg)	19kg 42 lbs
Dimensions (hwxwd in mm)	362 x 258 x 218 mm 14.3 x 10.2 x 8.6 inch
STANDARDS	
Safety	EN 60335-1, EN 60335-2-29
Emission / Immunity	EN55014-1, EN 61000-3-2 / EN 55014-2, EN 61000-3-3
Automotive Directive	2004/104/EC

1) Can be adjusted to 50Hz

2) Protection

- a. Output short circuit
- b. Overload
- c. Battery voltage too high
- d. Battery voltage too low
- e. Temperature too high
- f. 120VAC on inverter output
- g. Input voltage ripple too high

3) Non linear load, crest factor 3:1

4) Programmable relay which can be set for general alarm, DC undervoltage or genset start signal function

APPENDIX A Overview connections INVERTER 3k

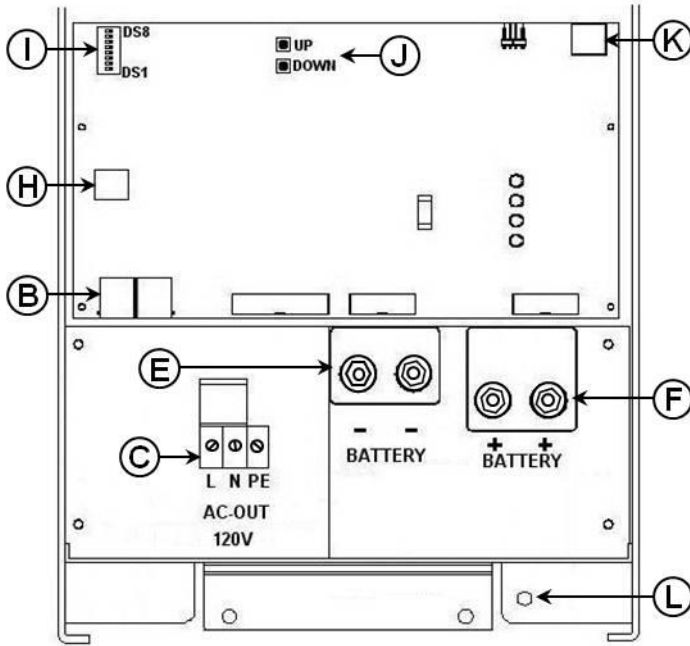

EN:

B	2x RJ45 connector for remote control and/or parallel / three-phase operation.
C	Load connection AC out: (left to right): L (phase), N (neutral), PE (ground).
E	Battery minus. Double M8 battery minus connection.
F	Battery plus. Double M8 battery positive connection.
H	Connections for remote switch: Short left and middle terminal to switch the Phoenix "on".
I	Dipswitches DS1 tm DS8 for set-up mode.
J	Pushbuttons for set-up mode.
K	Alarm contact: (left to right) NC, NO, COM
L	Primary ground connection (PE).

APPENDIX B: Block diagram

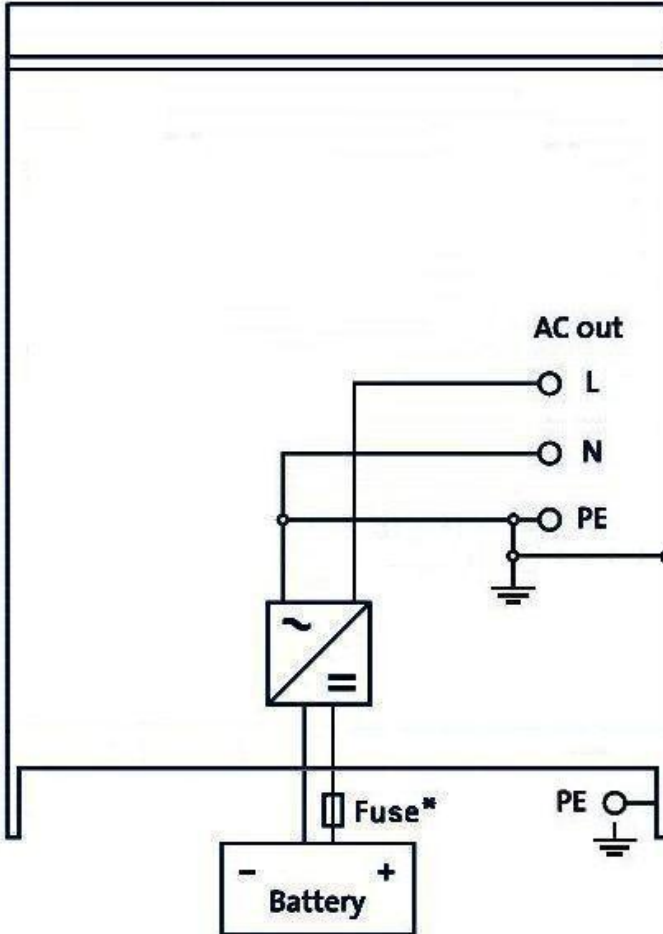

APPENDIX C: Parallel connection

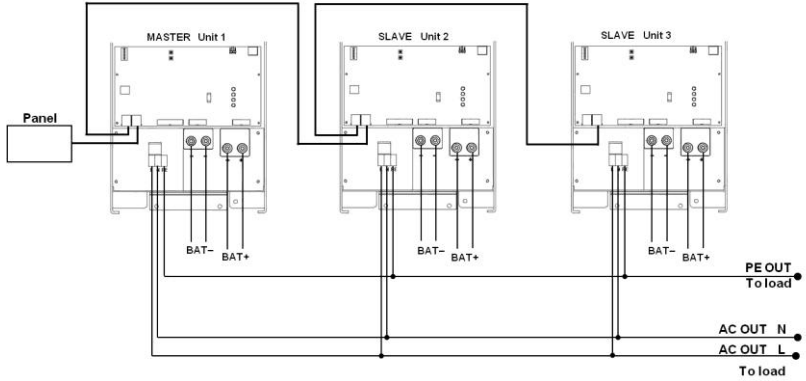

APPENDIX D: Three phase connection

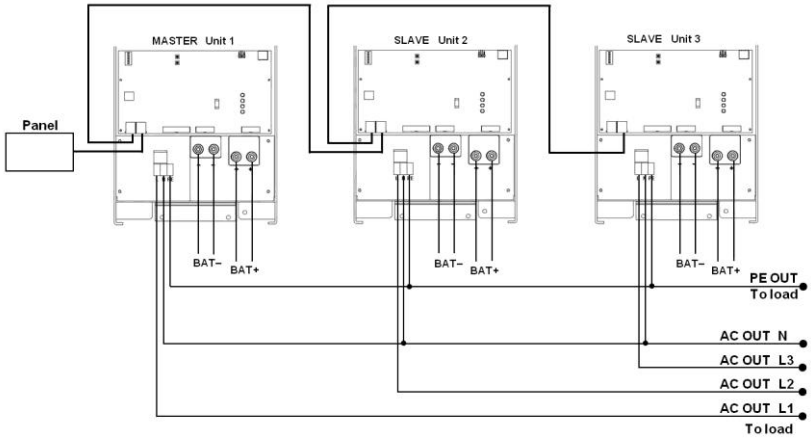

APPENDIX G: Dimensions

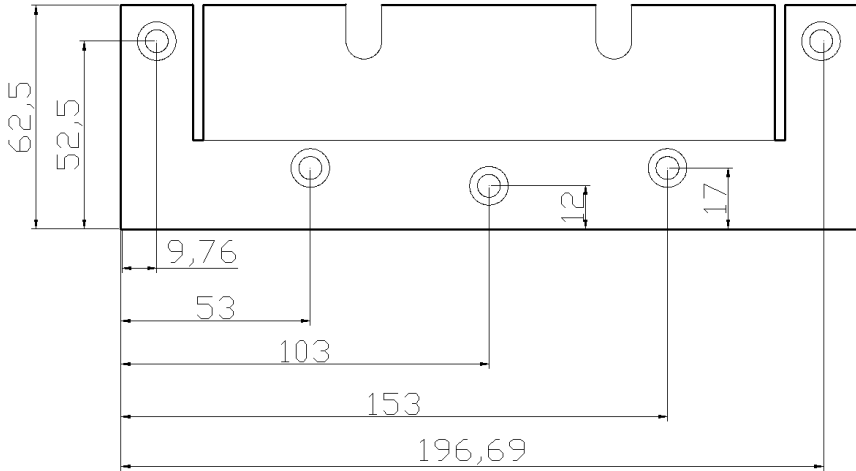

Dimensions 3k cabinet

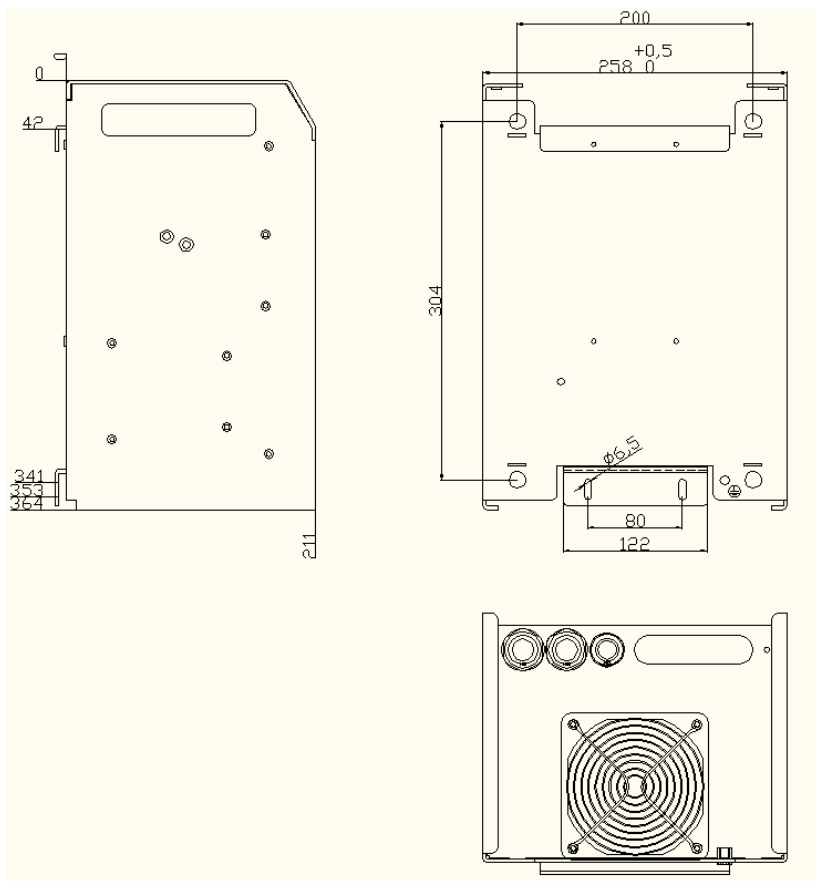

Victron Energy Blue Power

Distributor:

Serial number:

Version : 00

Date : 06 December 2010

Victron Energy B.V.

De Paal 35 | 1351 JG Almere

PO Box 50016 | 1305 AA Almere | The Netherlands

General phone : +31 (0)36 535 97 00

Customer support desk : +31 (0)36 535 97 03

Fax : +31 (0)36 535 97 40

E-mail : sales@victronenergy.com

www.victronenergy.com